

# 5 Axis

## CNC ROUTER TOOLING

by  
**ONSRUD  
CUTTER**

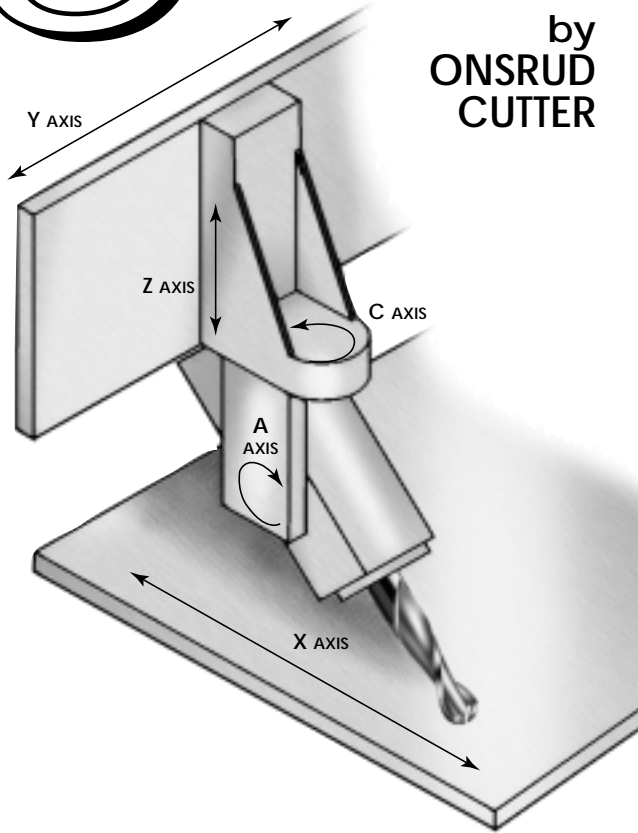

Five axis routers are replacing many multiple machine processes because of their reliability in trimming and contouring complex parts. They are also used in mold making of both plastic and wood forms.

*Onsrud Cutter has developed a line of solid carbide router bits designed with five axis routing in mind.*

**Extended reach** - these tools have a longer overall length to facilitate contour cutting.

**Less vibration** - five axis tools have geometry that reduces vibration in the cut caused by less than optimum fixturing.

**Spiral and straight cutting edges** - a choice of geometry to optimize the cutting action in a specific material.



### SOLID CARBIDE SE STRAIGHT

#### SERIES 61-000

These carbide tools were developed to combine the fast free cutting of O flute geometry with the tool life available from solid carbide particularly in small diameters



**Primary Usage:**  
Plastics

PART #	CED	CEL	SHK DIA	OAL
61-043	1/8	5/8	1/4	4
61-063	3/16	1	1/4	4
61-084	1/4	1 1/4	1/4	4
61-123	3/8	1 5/8	3/8	6



### SOLID CARBIDE DE STRAIGHT

#### SERIES 56-000

These carbide tools were developed as a general purpose tool to rout difficult-to-cut materials particularly in small diameters



**Primary Usage:**  
Hard plastics

PART #	CED	CEL	SHK DIA	OAL
56-063	3/16	5/8	1/4	4
56-086	1/4	1 1/4	1/4	4
56-124	3/8	1 5/8	3/8	6
56-164	1/2	2 1/8	1/2	6



### SOLID CARBIDE DE UPCUT SPIRAL BALL NOSE

#### SERIES 52-200BL

These double edge tools are designed for carving and modeling operations. Their improved tip geometry gives a superior cut to ballnose endmills, straight ball end cutters and standard core box cutters.



**Primary Usage:**  
Wood, wood composites, modeling foam, plastics.

PART #	CED	CEL	SHK DIA	OAL
52-240BL	1/8	1/2	1/4	3
52-260BL	3/16	3/4	1/4	3
52-280BL	1/4	1	1/4	4
52-320BL	3/8	1 1/4	3/8	4
52-360BL	1/2	1 1/2	1/2	5

# 5 Axis

## CNC ROUTER TOOLING AND ACCESSORIES



### SOLID CARBIDE DOUBLE EDGE O FLUTE STRAIGHT

SERIES 56-600

These tools were developed with free cutting O flute geometry along with a double flute design for smooth finish plastics.

Usage: Plastics



PART #	CED	CEL	SHK DIA	OAL
56-614	1/8	5/8	1/4	4
56-620	3/16	1	1/4	4
56-628	1/4	1 1/4	1/4	4
56-639	3/8	1	3/8	4
56-652	1/2	1	1/2	4
56-654	1/2	1 3/4	1/2	4
56-655	1/2	2 1/8	1/2	6

CED TOLERANCE + .000 -.004



### TOOL EXTENDER

SERIES 33-30

These extensions are designed to increase the overall reach of 3/8" and smaller router bits. These extensions are used mainly on CNC routers when routing three dimensional parts.



PART #	EXT OAL	SHK DIA	SHK LENGTH	HEAD DIA	COLLET
33-30	5	3/8	4	1/2	ER8
33-32	6 9/16	1/2	5 1/2	5/8	ER11
33-34	6 1/4	5/8	5 1/2	5/8	ER11
33-36	7	1/2	5 1/2	7/8	ER16
33-38	6 9/16	3/4	5 1/2	7/8	ER16

NOTE: Collet and Wrench sold separately.



### WRENCH

SERIES 33-40



Wrench to tighten ER extension collet nuts.

PART #	EXTENSION PART #
33-40	33-30
33-42	33-32/33-34
33-44	33-36/33-38



### COLLET

SERIES 33-50

Collets for tool extender

PART #	COLLET SIZE	TYPE
33-50	1/8	ER8
33-51	1/8	ER11
33-52	3/16	ER11
33-53	1/4	ER11
33-54	1/8	ER16
33-55	3/16	ER16
33-56	1/4	ER16
33-57	5/16	ER16
33-58	3/8	ER16



**Onsrud  
Cutter<sub>LP</sub>**

800 Liberty Drive  
Libertyville, IL 60048, U.S.A.

800-234-1560 • FAX: 847-362-5028  
E-MAIL: info@onsrud.com  
www.onsrud.com